

# MATRIX-VALUED HOLOMORPHIC CROSS-SECTIONS OVER AN ANNULUS

Jacob R. Cornejo\* and Kathryn McCormick  
California State University - Long Beach



## Abstract

Let  $\rho_1$  and  $\rho_2$  be two representations of the fundamental group of an annulus to the projective unitaries. For each representation as above, there is an associated continuous holomorphic function algebra. It is known that if the two said representations are equivalent, then the associated function algebras are completely isometrically isomorphic. This presentation will focus on an equivalence of unitary representations assuming a complete isometric isomorphism of continuous holomorphic function algebras defined on an annulus, where  $\rho_2$  is the trivial representation.

## Background and Motivation

In operator theory, one unresolved area of exploration is the classification of function algebras. In the context of operators algebras where the domain space of the operators are a fixed Riemann surface, and the range space is a  $PU_n(\mathbb{C})$ -bundle, there are some known results. For any of these particular algebras, there is an associated linear group representation of the fundamental group of the Riemann surface into the projective unitary group. What is known is that if the group representations are equivalent, then the algebras they are associated to are equivalent. The converse is unknown in general which is the aim of our project to illuminate.

## Notation and Context

### Notation:

- $[n] := \{1, 2, \dots, n\}$  for some positive integer  $n$ .
- For a matrix  $A$ , we define  $Ad(A)$  as a mapping taking elements  $X$  to  $A^*XA$ .
- Let  $\bar{R}$  be an annulus with boundary in the complex plane.
- Let  $A(\bar{R})$  denote the collection of functions  $f : \bar{R} \rightarrow \mathbb{C}$  such that  $f$  is continuous on  $\bar{R}$  and holomorphic on  $R$ .
- $\mathfrak{E}_\rho(\bar{R})$  denote a flat matrix  $PU_n(\mathbb{C})$ -bundle over  $\bar{R}$  where  $\rho : \pi_1(\bar{R}) \rightarrow PU_n(\mathbb{C})$  is a projective unitary representation of the fundamental group of  $\bar{R}$ .
- Let  $\mathcal{U}$  denote an open cover of the closed annulus.
- Let  $\Gamma_c(\bar{R}, \mathfrak{E}_\rho(\bar{R}))$  denote the  $C^*$ -algebra of continuous cross-sections of  $\mathfrak{E}_\rho(\bar{R})$ .
- Let  $\Gamma_h(\bar{R}, \mathfrak{E}_\rho(\bar{R}))$  denote the sub-algebra of continuous holomorphic sections.
- Let  $\mathcal{U}$  be an open cover of  $\bar{R}$  and let  $\{\sigma_U\}_{U \in \mathcal{U}}$  be a continuous cross-section of  $\mathfrak{E}_\rho(\bar{R})$  where each  $\sigma_U$  is an analytic function from  $U$  to  $M_n(\mathbb{C})$ .

### Context:

- We fix a unitary matrix  $A$ . The way  $H$  is defined to be, as seen in (2), is the unique real matrix such that  $A = e^{2\pi i H}$ .
- If  $\rho$  is the trivial representation then  $\Gamma_h(\bar{R}, \mathfrak{E}_\rho(\bar{R})) \cong M_n(A(\bar{R}))$ . This allows us to look at the entries of a matrix and utilize standard analytic function theory. For example, the entries of (2) are analytic functions on  $U$ .
- The elements  $U$  of the open cover  $\mathcal{U}$  are used to define branches of the logarithm  $\ln_U(x)$ .

## Result

**Theorem.** Let  $\bar{R}$  be an annulus. If  $\Gamma_h(\bar{R}, \mathfrak{E}_\rho(\bar{R}))$  is completely isometrically isomorphic to  $\Gamma_h(\bar{R}, \mathfrak{T}(\bar{R}))$ , then  $\mathfrak{E}_{\rho_1}(\bar{R})$  is flat unitarily equivalent to  $\mathfrak{T}(\bar{R})$ .

There are several stages that were done in order to acquire the above result. We are uncertain about whether the techniques used will extend to other Riemann surfaces and other representations. The setting for us is as stated in the above result, where  $\bar{R}$  is a closed annulus. The proof method is by arguing through contradiction. We first take a fixed diagonalized unitary matrix  $A \neq I_n$  of size  $n$  and use this to define the representation

$$\rho : \mathbb{Z} \rightarrow PU_n(\mathbb{C})$$

by  $\rho(1) = Ad(A)$ .

With appropriate translation, our goal is to show that the linear transformation defined as conjugation by the following

$$\mu_U(x) := \begin{pmatrix} \mu_{11,U}(x) & \cdots & \mu_{1,n-1,U}(x) & \mu_{1,n,U}(x) \\ \vdots & & \vdots & \vdots \\ \mu_{n-1,1,U}(x) & \cdots & \mu_{2,n-1,U}(x) & \mu_{2,n,U}(x) \\ \mu_{n,1,U}(x) & \cdots & \cdots & \mu_{n,n,U}(x) \end{pmatrix} \quad (1)$$

is constant and independent of  $U$ . A sufficient condition for this would be if products of the form  $\mu_{i,j,U}(x)\mu_{k,l,U}(x)$  are constant for all  $i, j, k, l \in [n]$  and are the same constant for all  $U \in \mathcal{U}$ . The construction of the entries of  $\mu_U(x)$  and the reason why it is necessary to show that conjugation by this matrix is constant can be seen in [1].

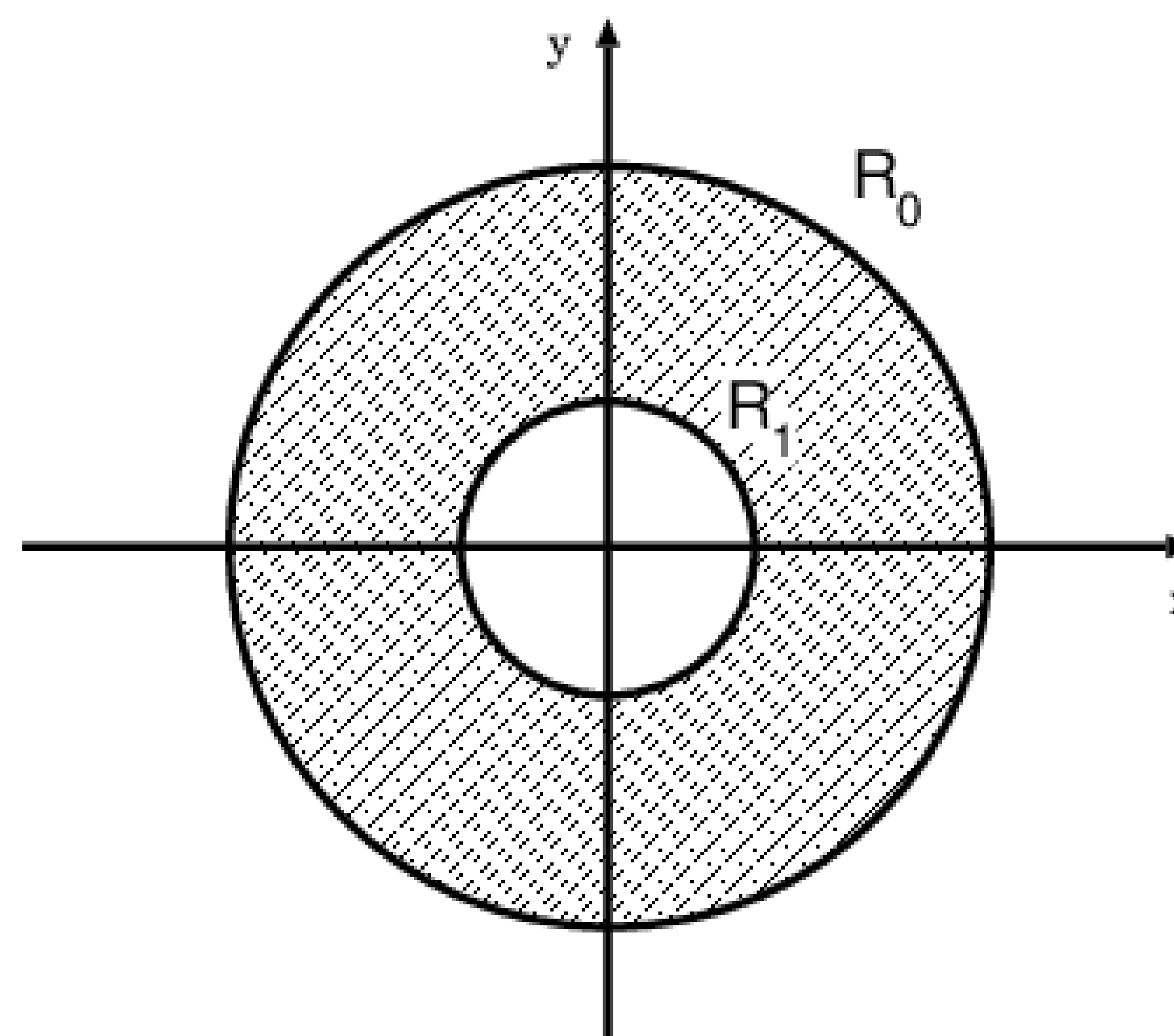

Figure 1: Annulus in complex plane[4].

**Lemma.** Conjugation by  $\mu_U(x)$  is constant.

The above lemma was a key component to justify the theorem's proof. When conjugation by  $\mu_U(x)$  is shown to be constant, then by the equivalence of matrix bundles, the matrices  $A$  and  $I$  should be equivalent. However, they are not equivalent and thus there is no complete isometric isomorphism between the holomorphic algebras. In order to acquire the lemma's result, one of the first steps was to construct enough holomorphic sections so as to show that all products of the  $\mu$  functions were constant. This was followed by exploiting the theory of *modulus automorphic functions* in [2] in order to account for the boundary components of the annulus. We elaborate on constructing sections.

## Constructing Cross-sections

In order to execute the proof of the lemma, we need to construct a family of holomorphic cross-sections to show  $\mu_U(x)$  is a constant, we opt to construct enough holomorphic sections in order to do so. We first consider a section

$$\sigma_U^B(x) = e^{-H \ln_U(x)} B(x) e^{H \ln_U(x)}, \quad (2)$$

which we map forward via the isometric isomorphism  $\phi : \Gamma_h(\bar{R}, \mathfrak{E}_\rho(\bar{R})) \rightarrow \Gamma_h(\bar{R}, \mathfrak{T}(\bar{R}))$

$$\phi(\sigma_U^B)(x) = \mu_U(x) \sigma_U^B(x) \mu_U(x)^*. \quad (3)$$

Following this representation and using results from [3] we showed  $\mu_{mj,U}(x)\mu_{lj,U}(x)$  are constant for all  $m, l, j \in [n]$ .

For the remaining terms we ended up constructing a family of cross-sections where we used the theory of *modulus automorphic functions* in [2] to show that all the  $\mu$  products are constant. Note the matrix  $A := \text{diag}(a_1, \dots, a_n)$  is unitary. As such, we may define  $K_{r,s}$  to be the real number such that  $e^{-2\pi i K_{r,s}} = \frac{a_r}{a_s}$  for which  $r < s$  for all  $r, s \in [n]$ , and  $K_{r,s} = K_{s,r}$  if  $r > s$ . This provides us with  $\binom{n}{2}$  of these  $K$ . Define  $F_{n,\mathbb{C}}(z) := (C_{j,k} e^{-K_{j,k} z})_{j,k}$  where  $C_{j,k} \equiv 0$  if  $j = k$ . It also turns out that  $F_{n,\mathbb{C}}(z)$  is analytic and equivariant for any choice of constants  $C_{j,k}$  because

$$F_{n,\mathbb{C}}(z + 2\pi i) = A^{-1} F_{n,\mathbb{C}}(z) A. \quad (4)$$

As before, we can map to the trivial bundle using  $\phi$  as follows to acquire

$$\phi(F_{n,\mathbb{C}}(\ln_U(x))) = \mu_U(x) F_{n,\mathbb{C}}(\ln_U(x)) \mu_U(x)^* \quad (5)$$

## Acknowledgements

The presenter is very grateful for Prof. Kathryn McCormick's advice, mentorship, and collaboration. The project was funded by the CSULB Green Family Endowment.

## References

- [1] K. McCormick, *Operator Algebras, Matrix Bundles, and Riemann Surfaces*, University of Iowa, 2018.
- [2] D. Sarason, *The  $H^p$  Spaces of an Annulus*. Providence, R.I: American Mathematical Society, 1965.
- [3] W. Rudin, *Real and Complex Analysis*, McGraw Hill, 1979.
- [4] C.F. Bødigheimer, *Configuration Models For Moduli Spaces of Riemann surfaces with boundary* - Scientific Figure on ResearchGate. Available from: [https://www.researchgate.net/figure/Annulus-in-complex-plane\\_fig3\\_225745307](https://www.researchgate.net/figure/Annulus-in-complex-plane_fig3_225745307) [accessed 14 Apr, 2022]